

CHIPPER AND PROFILER KNIVES

For Veisto Hew Saw

Design

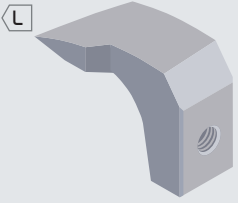
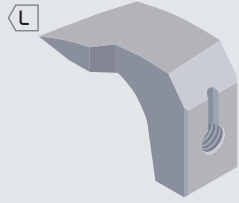
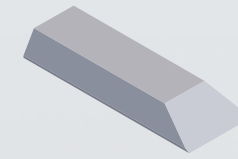
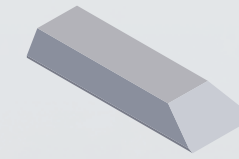
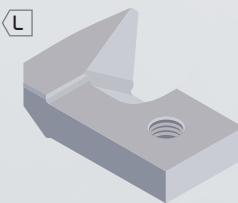
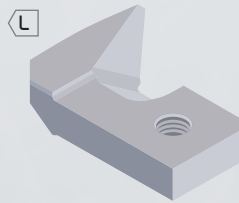

	<p>Knife 71.5 x 53 x 34/28 mm 1 M12 thread</p> <p>HDS-No. BC 10040 L / 10041 R HDS-No. TC 21147 L / 21148 R</p>		<p>Knife 71.5 x 53 x 34/28 mm 1 M12 thread with groove in spine</p> <p>HDS-No. BC 21522 L / 21523 R HDS-No. TC 21581 L / 21582 R</p>
	<p>Knife 82 x 25 x 10 mm 1 M6 thread in spine</p> <p>HDS-No. BC 10218 HDS-No. TC 20386</p>		<p>Knife 82 x 30 x 10 mm 1 M6 thread in spine</p> <p>HDS-No. BC 10500 HDS-No. TC 18985</p>
	<p>Knife 94.6 x 75/45 x 20/16 mm 1 M16 thread</p> <p>HDS-No. BC 10533 L / 10534 R HDS-No. TC 16529 L / 16530 R</p>		<p>Knife 100.8 x 76.11/45 x 20/16 mm 1 M16 thread</p> <p>HDS-No. BC 10050 L / 10051 R HDS-No. TC 16525 L / 16527 R</p>

HOGGING AND COUNTER KNIVES

For Klöckner (partly Haas)

Design

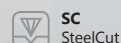
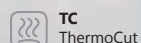
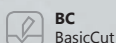

	<p>Hogging knife 430 x 85 x 14 mm 2 M8 threads in spine</p> <p>HDS-No. BC 10060</p>		<p>Hogging knife 530 x 85 x 14 mm 2 M8 threads in spine</p> <p>HDS-No. BC 10791</p>
	<p>Hogging knife 630 x 120 x 20 mm 2 M8 threads in spine</p> <p>HDS-No. BC 10062</p>		<p>Counter knife 930 x 60 x 40 mm 12 bores, one side countersunk</p> <p>HDS-No. BC 10065</p>
	<p>Hogging knife 930 x 210 x 20 mm 10 notches, 2 recesses, 2 M8 threads, 4 M8 threads in spine</p> <p>HDS-No. BC 10066</p>		<p>HDS SoWa With our "SoWa Sawmill Optimised Tool Design" we can supply any sawmill knife to drawing or sample.</p>



HOGGING AND COUNTER KNIVES

For Pallmann

Design



BC
BasicCut



PC
PitchCut



GC
GeoCut



TC
ThermoCut



SC
SteelCut

	<p>Hogging knife 600 x 100 x 20 mm 6 long grooves 5 M10 threads in spine HDS-No. BC 15347</p>		<p>Hogging knife 665 x 295 x 25 mm 7 notches 2 recesses in spine 2 M12 threads in spine HDS-No. BC 17455</p>
	<p>Hogging knife 765 x 295 x 25 mm 8 notches 2 recesses in spine 2 M12 threads in spine HDS-No. BC 26734</p>		<p>Hogging knife 780 x 220 x 20 mm 9 notches 2 recesses in spine 2 M10 threads in spine HDS-No. BC 11438</p>
	<p>Hogging knife 870 x 295 x 25 mm 9 notches 2 recesses in spine 2 M12 threads in spine HDS-No. BC 13587</p>		<p>Hogging knife 930 x 220 x 20 mm 10 notches 2 recesses in spine 2 M10 threads in spine HDS-No. BC 10008</p>
	<p>Hogging knife 930 x 295 x 25 mm 10 notches 2 recesses in spine 2 M12 threads in spine HDS-No. BC 14170</p>		<p>Hogging knife 1130 x 220 x 20 mm 12 notches 2 recesses in spine 2 M10 threads in spine HDS-No. BC 11390</p>
	<p>Hogging knife 1530 x 220 x 25 mm 3 bores, one side countersunk 3 M16 threads in spine HDS-No. BC 11065</p>		

HDS SoWa
With our "SoWa Sawmill Optimised Tool Design" we can supply any sawmill knife to drawing or sample.

HOGGING AND COUNTER KNIVES

For Rudnick & Enners

Design



BC
BasicCut



PC
PitchCut



GC
GeoCut



TC
ThermoCut



SC
SteelCut

	<p>Hogging knife 220 x 220 x 20 mm 3 notches 2 M10 threads in spine HDS-No. BC 12840</p>		<p>Hogging knife 530 x 130 x 12 mm 6 notches 2 recesses in spine 2 M8 threads in spine HDS-No. BC 11448</p>
	<p>Hogging knife 630 x 130 x 12 mm 7 notches 2 recesses in spine 2 M8 threads in spine HDS-No. BC 10027</p>		<p>Hogging knife 630 x 160 x 15 mm 7 notches 2 recesses in spine 2 M10 threads in spine HDS-No. BC 10009</p>
	<p>Hogging knife 780 x 160 x 15 mm 9 notches 2 recesses in spine 2 M10 threads in spine HDS-No. BC 10026</p>		<p>Hogging knife 780 x 220 x 20 mm 9 notches 2 recesses in spine 2 M10 threads in spine HDS-No. BC 10266</p>
	<p>Hogging knife 930 x 220 x 20 mm 10 notches 2 recesses in spine 2 M10 threads in spine HDS-No. BC 10067</p>		<p>Counter knife 1020 x 80 x 15 mm HDS-No. BC 10271</p>
	<p>Counter knife 1040 x 120 x 20 mm HDS-No. BC 10674</p>		<p>Counter knife 1250 x 145 x 29 mm 12 long grooves HDS-No. BC 10276</p>
	<p>Counter knife 1450 x 145 x 29 mm 15 long grooves HDS-No. BC 13424</p>		
		<p>HDS SoWa With our "SoWa Sawmill Optimised Tool Design" we can supply any sawmill knife to drawing or sample.</p>	





HOGGING AND COUNTER KNIVES

For Vecoplan

Design



BC
BasicCut



PC
PitchCut











GC
GeoCut



TC
ThermoCut



SC
SteelCut

	<p>Hogging knife 580 x 90 x 14 mm 4 M8 threads in spine</p> <p>HDS-No. BC 11696</p>		<p>Hogging knife 580 x 120 x 14 mm 4 M8 threads in spine</p> <p>HDS-No. BC 17458</p>
	<p>Counter knife 585 x 25 x 5 mm</p> <p>HDS-No. BC 15340</p>		<p>Hogging knife 680 x 120 x 14 mm 4 M8 threads in spine</p> <p>HDS-No. BC 13763</p>
	<p>Counter knife 685 x 25 x 5 mm</p> <p>HDS-No. BC 12606</p>		<p>Hogging knife 780 x 120 x 14 mm 2 M8 threads in spine</p> <p>HDS-No. BC 10265</p>
	<p>Hogging knife 780 x 160 x 20 mm 4 M12 threads in spine</p> <p>HDS-No. BC 14364</p>		<p>Counter knife 785 x 25 x 5 mm</p> <p>HDS-No. BC 12818</p>

